

# TREX700/800 SERIES TAIL BOOM MOUNT ADAPTERS AT700-TBMA (SS 17-4PH)

**IMPORTANT:** ADD HIGH-STRENGTH, RED LOCTITE (263 OR 271 PREFERRED) TO THREADS BEFORE INSTALLATION. THIS WILL PROVIDE A NEAR-PERMANENT AND VIBRATION-RESISTANT BOND BETWEEN COMPONENTS. FIRMLY TIGHTEN LOWER STABILIZER ADAPTER WITH 8MM (5/16") WRENCH OR HEX SOCKET. **REPEAT BOTH SIDES.**

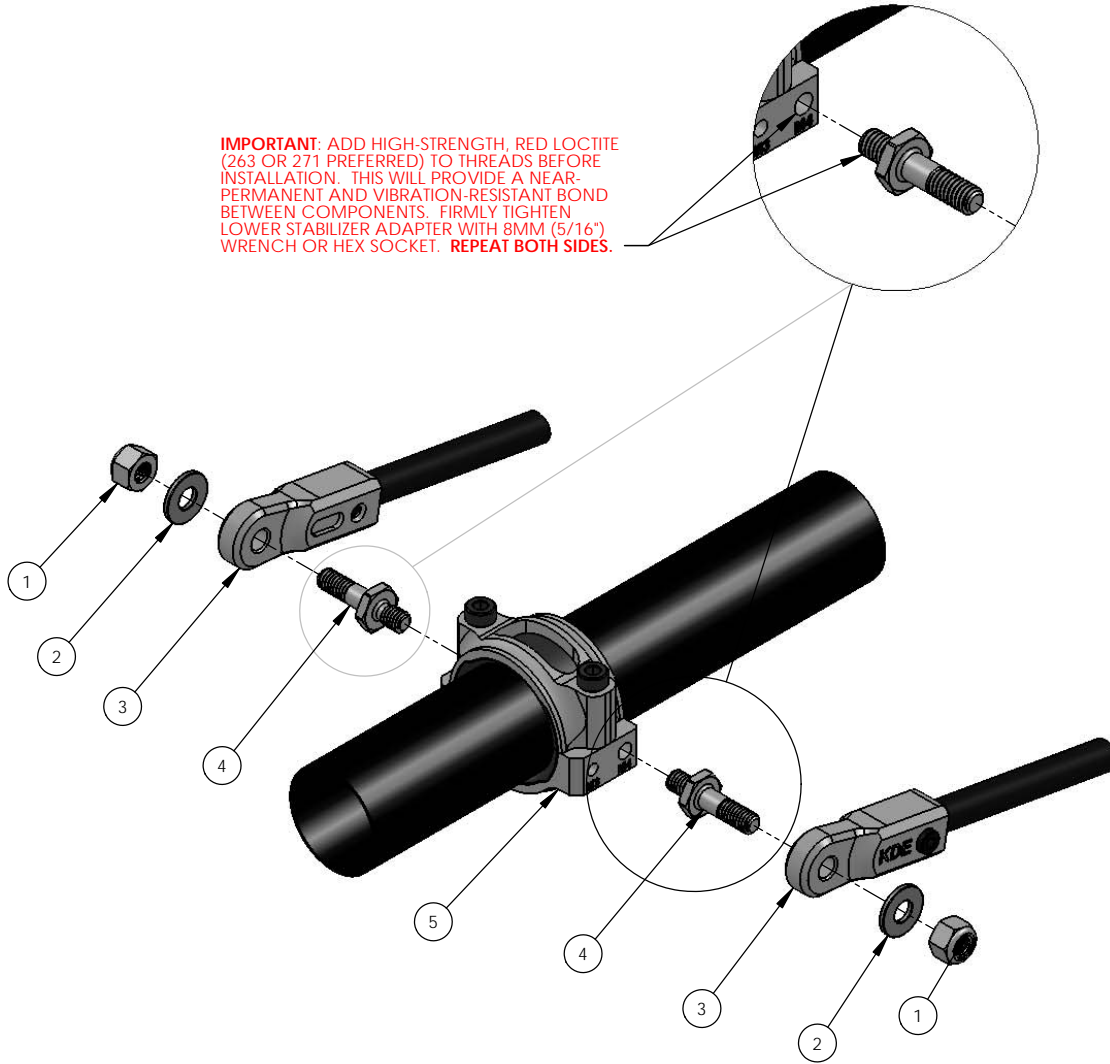

ITEM NO.	DESCRIPTION	QTY.
1	SAB GOBLIN 500 SERIES TAIL PIN [H0264-S] (INCLUDED IN ORIGINAL KIT)	2
2	FLANGED RADIAL BALL BEARING F682XZZ [HC400-S] (INCLUDED IN ORIGINAL KIT)	2
3	KDE DIRECT 700/800 SERIES PERFORMANCE BOOM SUPPORT ASSEMBLY (SOLD SEPARATELY, KDE700-PBSA OR KDE800-PBSA)	2
4	KDE DIRECT 700/800 SERIES TAIL BOOM MOUNT ADAPTERS	2
5	KDE DIRECT 550/600/700/800 SERIES TAIL BOOM SUPPORT MOUNT (SOLD SEPARATELY, AT550/600/700-TBSM)	1

**NOTE:** THE TREX 700/800 SERIES TAIL BOOM MOUNT ADAPTERS ARE THE IDEAL SOLUTION FOR PREVENTING UNWANTED LOOSENING AND FAILURE OF THE TAIL BOOM BRACES CAUSED BY THE HIGH-VIBRATION NATURE OF THE HELICOPTER. USING A HIGH-STRENGTH, SS 17-4 PH CONSTRUCTION AND CNC-PRECISION MACHINING, THE CHANCE OF FAILURE IS GREATLY REDUCED AND PROVIDES A SIMPLE, HASSLE-FREE METHOD FOR TAIL BOOM SUPPORT ASSEMBLY INSTALLATION AND REMOVAL.

BEFORE INSTALLING THE TAIL BOOM MOUNT ADAPTERS, APPLY RED LOCTITE (263 OR 271 PREFERRED) TO THE THREADS SHOWN IN THE DIAGRAM. ONCE LOCTITE HAS BEEN APPLIED, FIRMLY TIGHTEN THE ADAPTERS TO THE LOWER STABILIZER MOUNT USING AN 8MM (5/16") WRENCH OR HEX SOCKET TO FIRMLY BOND THE COMPONENTS.

**PLEASE NOTE:** THE THREADS HAVE BEEN MACHINED TO INCLUDE A THREAD-LOCK GEOMETRY TOWARDS THE LAST FEW TURNS, THEREBY PRODUCING A MECHANICAL LOCK BETWEEN COMPONENTS TO FURTHER ENHANCE THE HOLDING STRENGTH AND RESISTANCE TO VIBRATION. RESISTANCE WILL BE FELT WHILE THREADING THE ADAPTERS INTO THE LOCKING SECTION, BUT CONTINUE TO TIGHTEN UNTIL THE INNER SURFACE OF THE HEX ADAPTER IS FLUSH WITH THE SIDEWALL OF THE LOWER STABILIZER MOUNT. **ALLOW TO CURE A MINIMUM OF 1 HOUR BEFORE FLIGHT.**

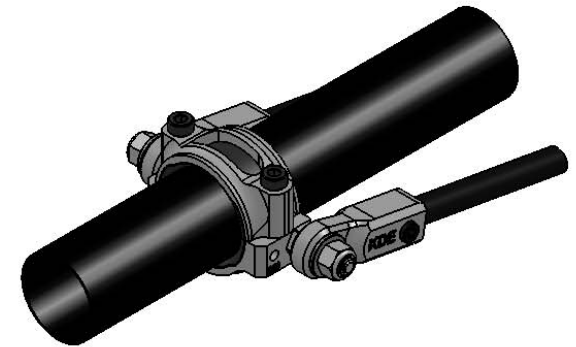

www.KDEDirect.com  
AT700-TBMA