

GOBLIN630/700/770 SERIES BATTERY TRAY SYSTEM ASSEMBLY V2 SG630/700/770-BTSA-V2 (AL 6061-T6, AISI 1095 BTHC)

STEP 1 ASSEMBLE PUSH LOCK LEVER TO PRIMARY BASE FRAME V2

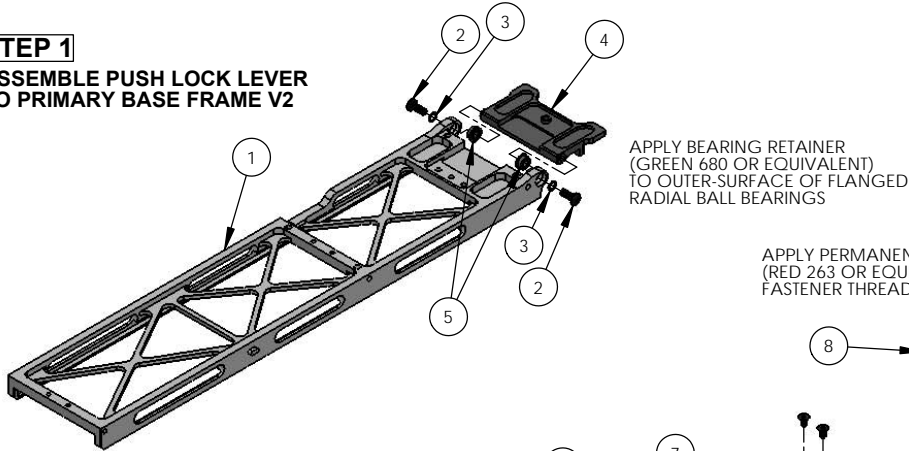

STEP 2 ASSEMBLE SPRING STEEL PLATE AND OPTIONAL CARBON BATTERY SUPPORT TRAY

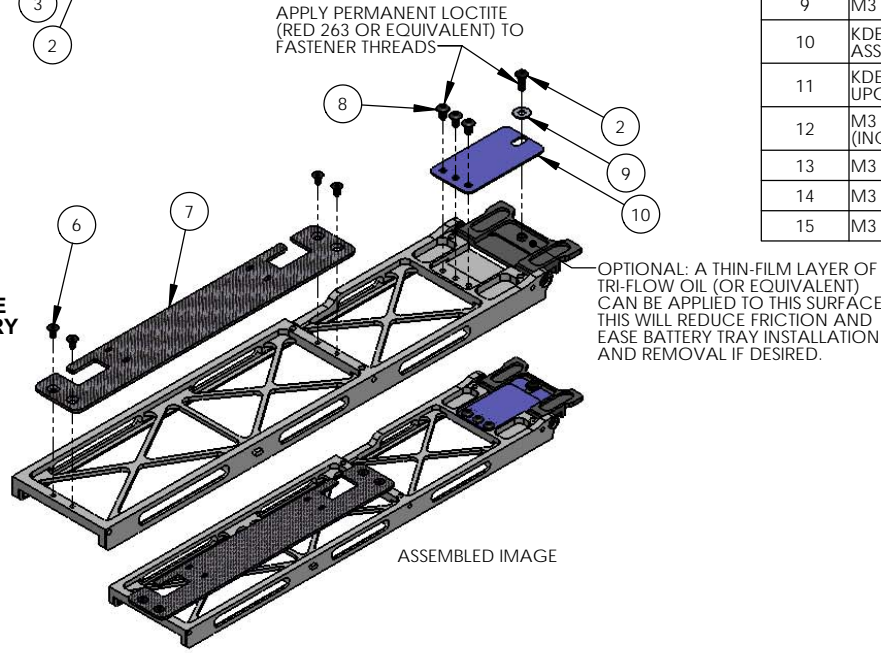

STEP 3 INSTALL BATTERY TRAY UPGRADE V2

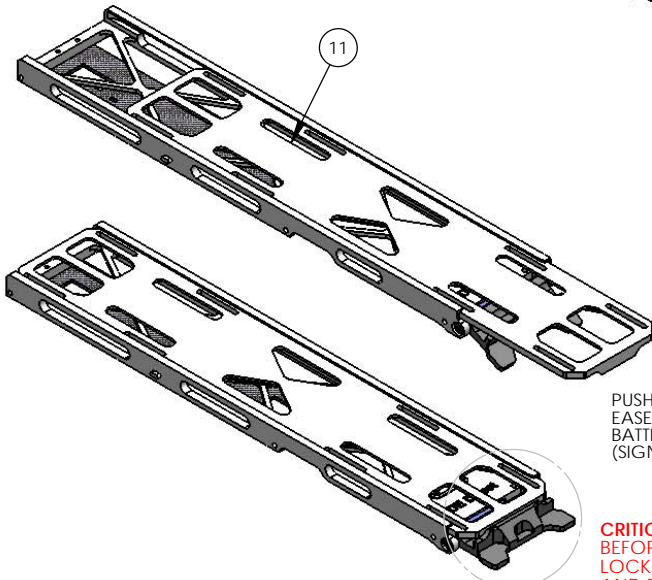

CRITICAL NOTE:
BEFORE FLIGHT, VISUALLY VERIFY
LOCK LEVER IS PROPERLY ENGAGED
AND FLUSH WITH BATTERY TRAY

STEP 4 (OPTIONAL) INSTALL KONTRONIK KOSMIK ESC SERIES

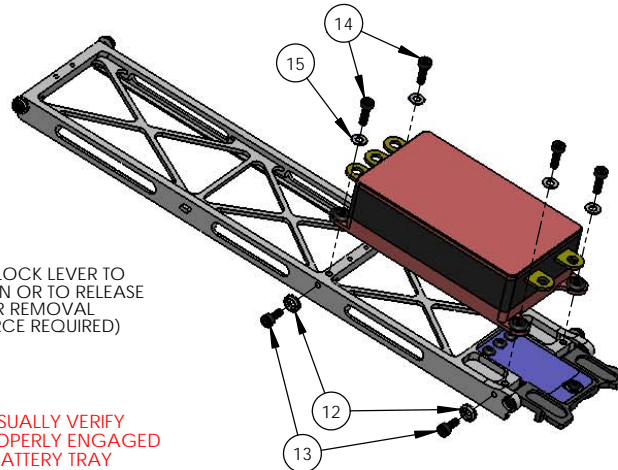

NOTE: THE GOBLIN 630/700/770 BATTERY TRAY SYSTEM ASSEMBLY V2 PROVIDES THE BEST SUPPORT FOR THE LIPOS DURING FLIGHT, WITH AN ULTRA-LIGHT AND HIGH-STRENGTH FRAME DESIGN THAT PROVIDES EXCEPTIONAL SUPPORT AND HOLDING-STRENGTH FOR THE LIPOS. THE ASSEMBLY USES AN INNOVATIVE AND PATENT PENDING LOCKING MECHANISM FOR FAST AND HASSLE-FREE INSTALLATION AND REMOVAL OF THE LIPOS.

PLEASE PAY ATTENTION TO THE INSTRUCTIONS AND TAKE YOUR TIME WHEN INSTALLING THE ASSEMBLY. **MAKE SURE TO APPLY MEDIUM-STRENGTH LOCTITE (BLUE 243 OR EQUIVALENT) TO ALL SCREWS DURING ASSEMBLY UNLESS OTHERWISE NOTED.**

STEP 1: INSTALL THE PUSH LOCK LEVER TO THE PRIMARY BASE FRAME V2, MAKING SURE TO APPLY BEARING RETAINER (LOCTITE 680 OR EQUIVALENT) TO THE OUTER-SURFACE OF THE FLANGED RADIAL BALL BEARINGS AND MEDIUM-STRENGTH LOCTITE (BLUE 243 OR EQUIVALENT) TO THE BUTTON HEAD SOCKET HEAD CAP SCREWS. FULLY-TIGHTEN ALL HARDWARE AND CHECK FOR SMOOTH ROTATION OF THE PUSH LOCK LEVER.

STEP 2: INSTALL THE SPRING STEEL PLATE AND CARBON BATTERY SUPPORT (OPTIONAL), MAKING SURE TO APPLY PERMANENT-STRENGTH LOCTITE (RED 263 OR EQUIVALENT) TO THE BUTTON HEAD SOCKET HEAD CAP SCREWS AND FULLY-TIGHTEN ALL HARDWARE. MAKE SURE THE EXTENDED 4MM POST OF THE PUSH LOCK LEVER IS PROPERLY INSTALLED INTO THE SLOT POCKET OF THE SPRING STEEL PLATE.

STEP 3: INSTALL THE BATTERY TRAY UPGRADE V2 AND TEST MECHANICS. PUSH DOWN ON THE PUSH LOCK LEVER TO EASE INSTALLATION OR TO RELEASE BATTERY TRAY FOR REMOVAL. DUE TO THE REQUIRED STRENGTH OF THE HOLD IN FLIGHT, SIGNIFICANT FORCE IS REQUIRED TO RELEASE THE TRAY.

STEP 4 (OPTIONAL): THE PRIMARY BASE FRAME V2 EDITION HAS FOUR M3 THREADED HOLES FOR MOUNTING THE KONTRONIK KOSMIK ESC SERIES. INSTALL USING THE INCLUDED M3 STANDARD WASHERS AND SOCKET HEAD CAP SCREWS (M3 X 0.5 X 10MM).

INSTALL BATTERY TRAY SYSTEM ASSEMBLY V2 INTO GOBLIN 630/700/770 SERIES HELICOPTER, USING SAME HARDWARE AND LOCATION AS THE STOCK CARBON BATTERY TRAY ASSEMBLY. **WHEN THE KONTRONIK KOSMIK ESC IS INSTALLED, USE THE INCLUDED SOCKET HEAD CAP SCREWS (M3 X 0.5 X 8MM) IN THE LOCATIONS SHOWN IN STEP 4 TO PREVENT INTERFERENCE BETWEEN HARDWARE (ITEM #13).**

CRITICAL NOTE: BEFORE FLIGHT, VISUALLY VERIFY LOCK LEVER IS PROPERLY ENGAGED AND FLUSH WITH BATTERY TRAY, AND CHECK BATTERY TRAY IS PROPERLY SEATED AND UNABLE TO MOVE WHEN INSTALLED.

ITEM NO.	DESCRIPTION	QTY.
1	KDE DIRECT SAB GOBLIN 630/700/770 SERIES BATTERY TRAY SYSTEM ASSEMBLY PRIMARY BASE FRAME V2	1
2	M3 x 0.5 x 8MM BUTTON HEAD SOCKET HEAD CAP SCREW	3
3	M3 x 0.3MM ROUND HOLE SHIM	2
4	KDE DIRECT SAB GOBLIN 630/700/770 SERIES BATTERY TRAY SYSTEM ASSEMBLY PUSH LOCK LEVER	1
5	MF63ZZ FLANGED RADIAL BALL BEARING	2
6	M2.5 x 0.45 x 5MM FLAT HEAD SOCKET HEAD CAP SCREW (INCLUDED IN ORIGINAL KIT)	4
7	SAB GOBLIN 630/700/770 SERIES CARBON BATTERY SUPPORT (INCLUDED IN ORIGINAL KIT)	1
8	M3 x 0.5 x 5MM BUTTON HEAD SOCKET HEAD CAP SCREW	3
9	M3 x 8MM SPECIALTY FLAT WASHER	1
10	KDE DIRECT SAB GOBLIN 630/700/770 SERIES BATTERY TRAY SYSTEM ASSEMBLY SPRING STEEL PLATE	1
11	KDE DIRECT SAB GOBLIN 630/700/770 SERIES BATTERY TRAY UPGRADE V2	1
12	M3 FINISHING WASHER (INCLUDED IN ORIGINAL KIT)	4
13	M3 x 0.5 x 8MM SOCKET HEAD CAP SCREW	4
14	M3 x 0.5 x 10MM SOCKET HEAD CAP SCREW	4
15	M3 STANDARD WASHER	4



www.KDEDirect.com
SG630/700/770-BTSA-V2